

IBM

**OPD CUSTOMER ENGINEERING
I/O Reference Manual
Section 4**

Reprinted July, 1966

F/N 241-5311-0

All rights to reproduce this material are reserved by IBM.

CONTENTS

SECTION 4 PRODUCT SPECIFICATION (73)

DIAGNOSTIC AIDS

BCD Function Guide.....	9
Component Layout.....	10
Tilt Rotate Schedule.....	8
Typehead Layout.....	8

TIMING CHARTS

Carrier Return and Index.....	2
Print Selection.....	1
Ribbon Shift (1 & 2 Magnet).....	3
Shift (L.C. & U.C.).....	4
Space, Backspace and Tab.....	2

WIRING DIAGRAMS

BCD Keyboard Arrangement.....	7
Correspondence Keyboard Arrangement.....	5
MT/ST Keyboard Arrangement.....	6

MISCELLANEOUS

Electrical Specifications.....	1
Operating Speeds.....	1

ELECTRICAL SPECIFICATIONS			
Component	Voltage ¹	Current ²	D.C. Resistance (Ohms)
Motor	115	1.0 amp	
K/B Lock Solenoid	48	160	329 to 397
Ribbon Shift Magnet (1 Magnet)	48	160	345 to 455
Red Ribbon Shift (2 Magnet) and U.C. Shift Magnets	48	250	221 to 259
All Other Magnets	48	125	432 to 518
All Contacts	Shall operate with 10 volts at 40 ma. or 48 volts with 300 ma.		
1. Machine must perform all functions at $\pm 10\%$ of specified voltages. 2. Maximum currents at (in ma.) specified operating voltages.			

Magnet and Solenoid Operating Speeds	
Component	Maximum Pick Time (48 V DC)
K/B Lock Solenoid	55 ms.
Red Ribbon Shift Magnet (1 or 2 magnet mechanism)	12 ms.
All Other Magnets	10 ms.

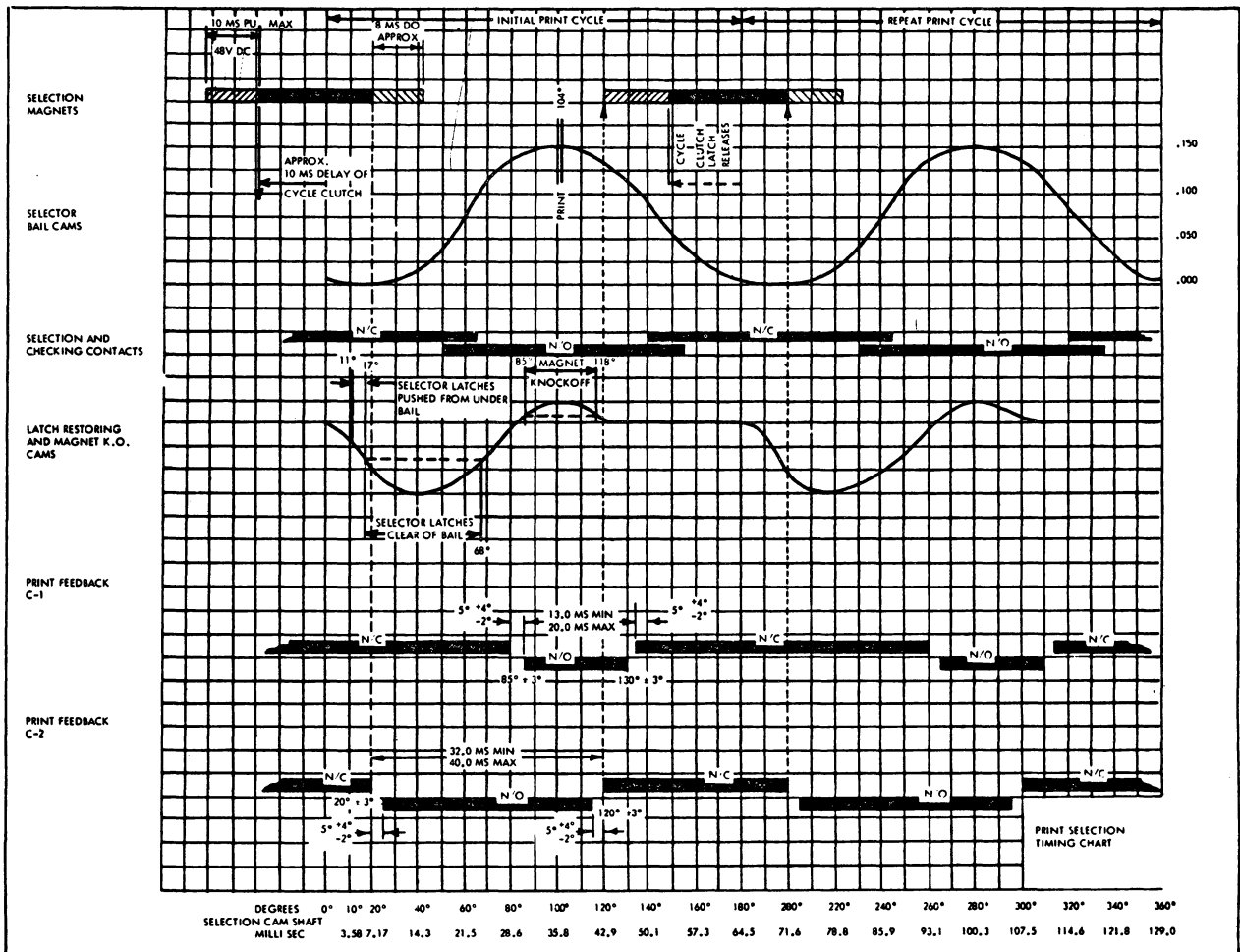

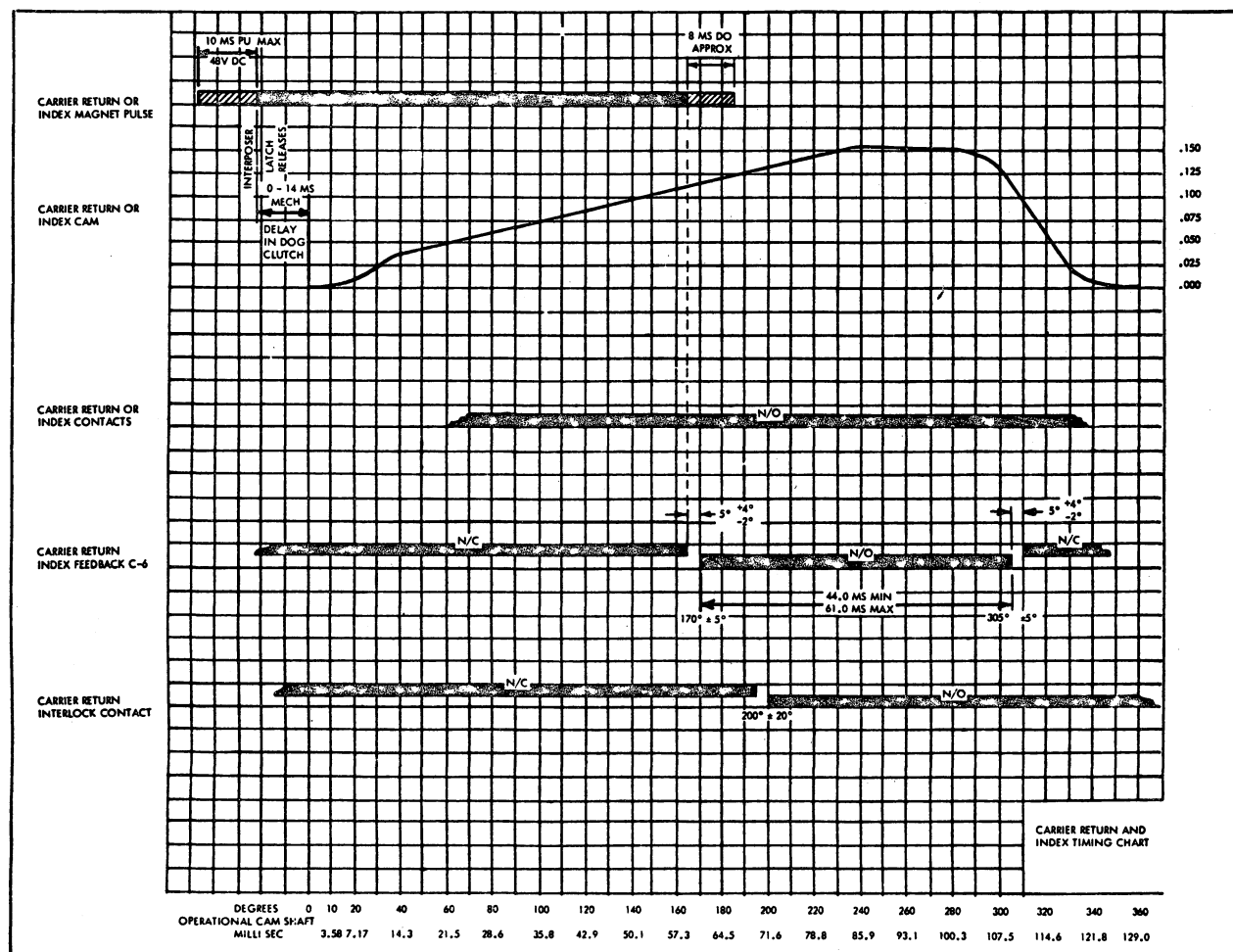
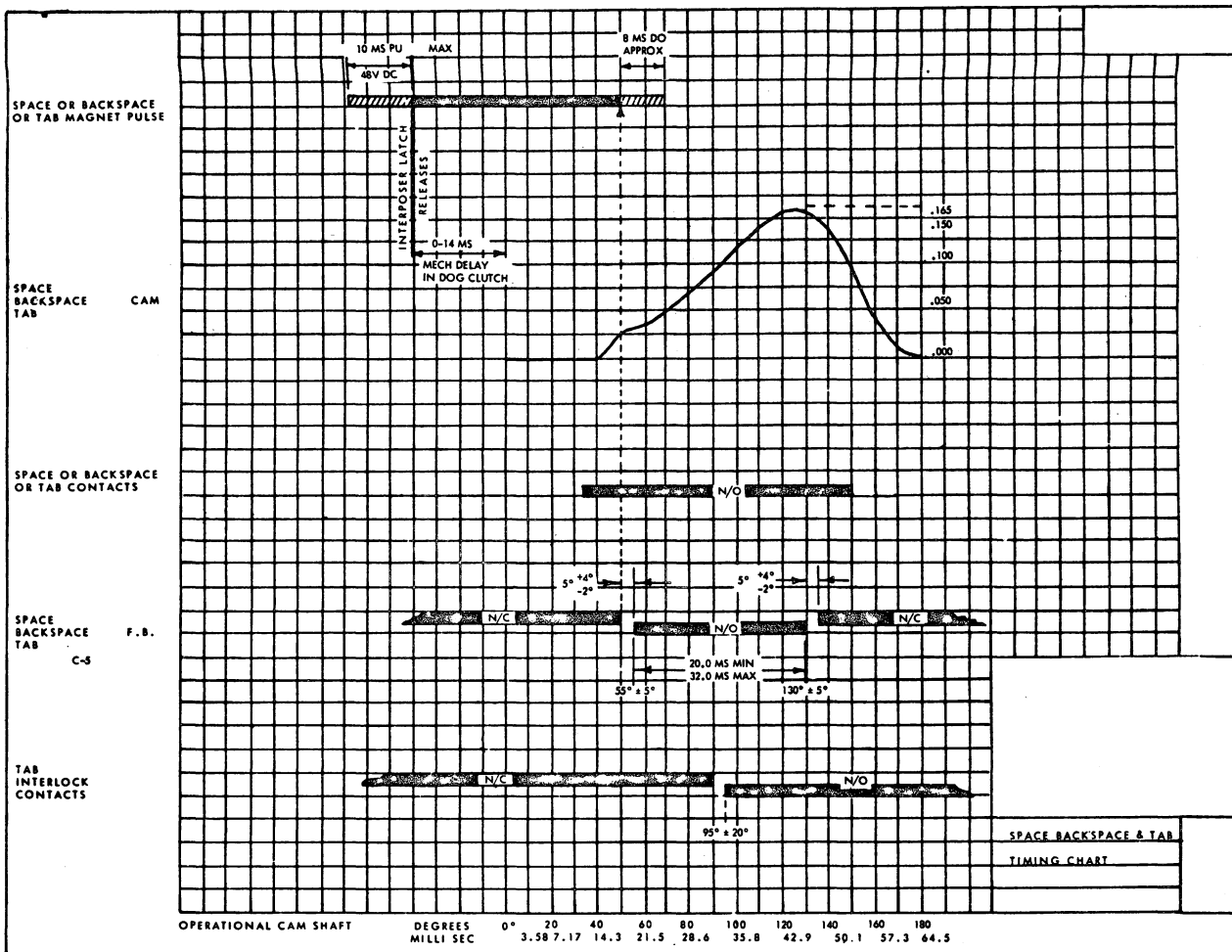

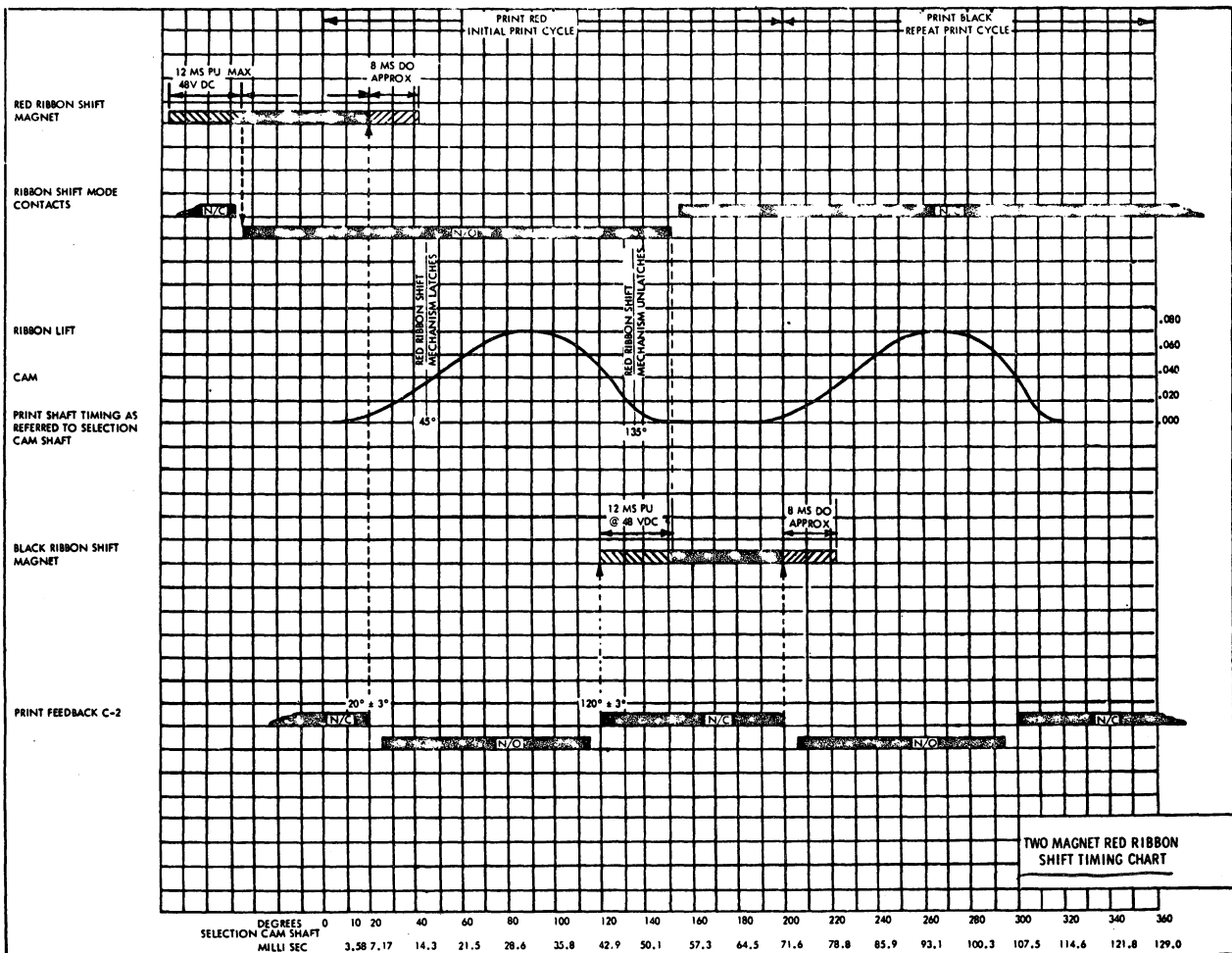
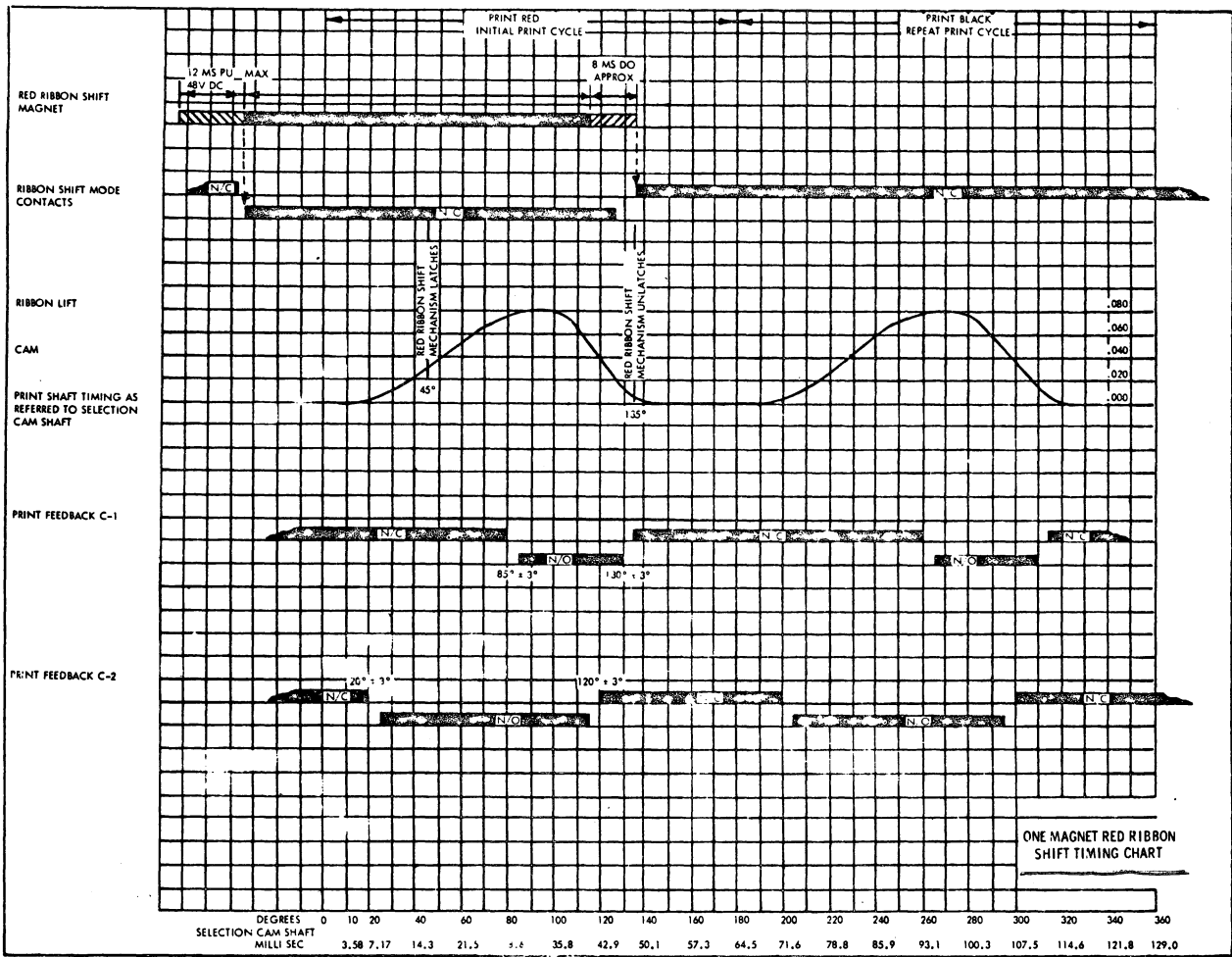

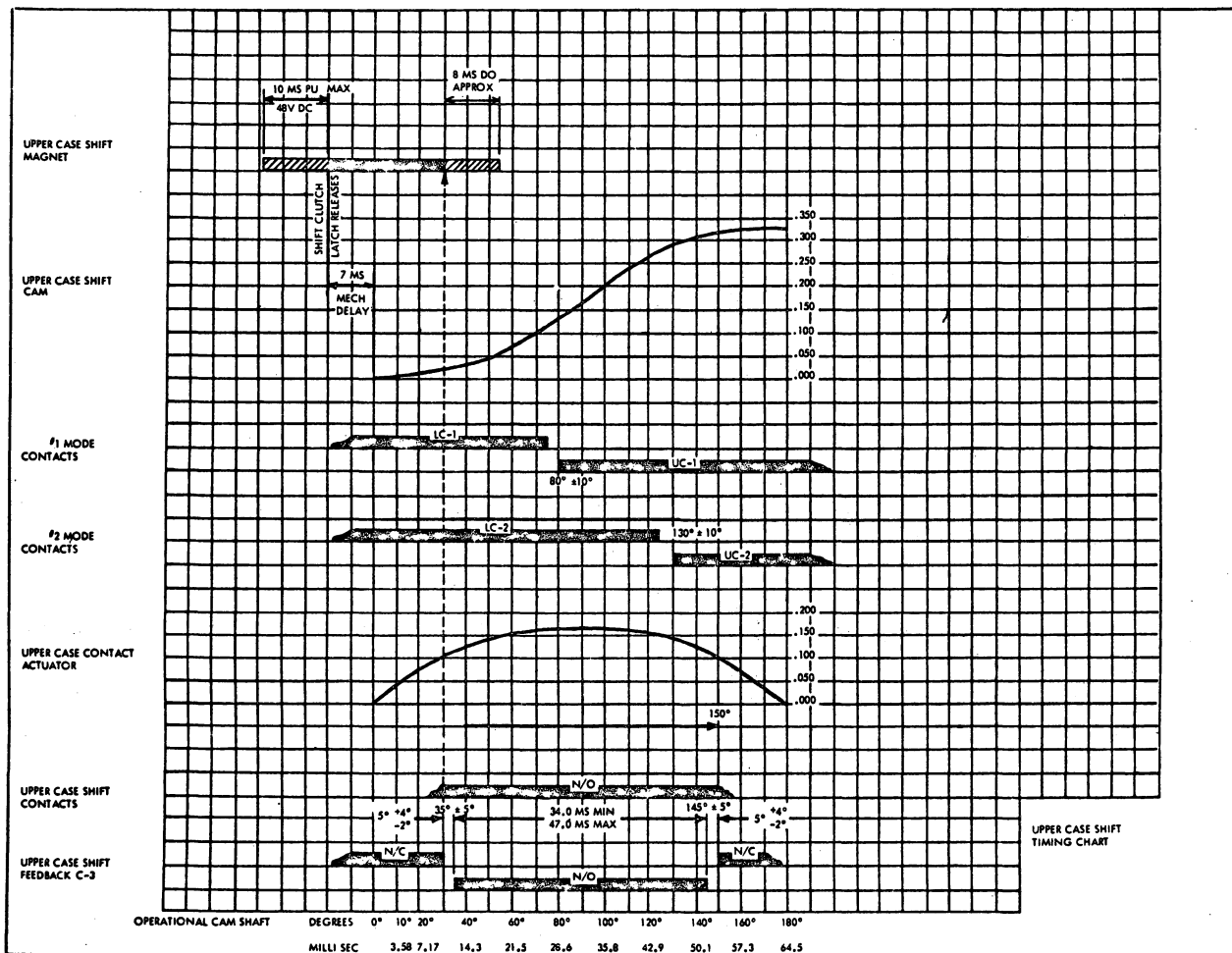
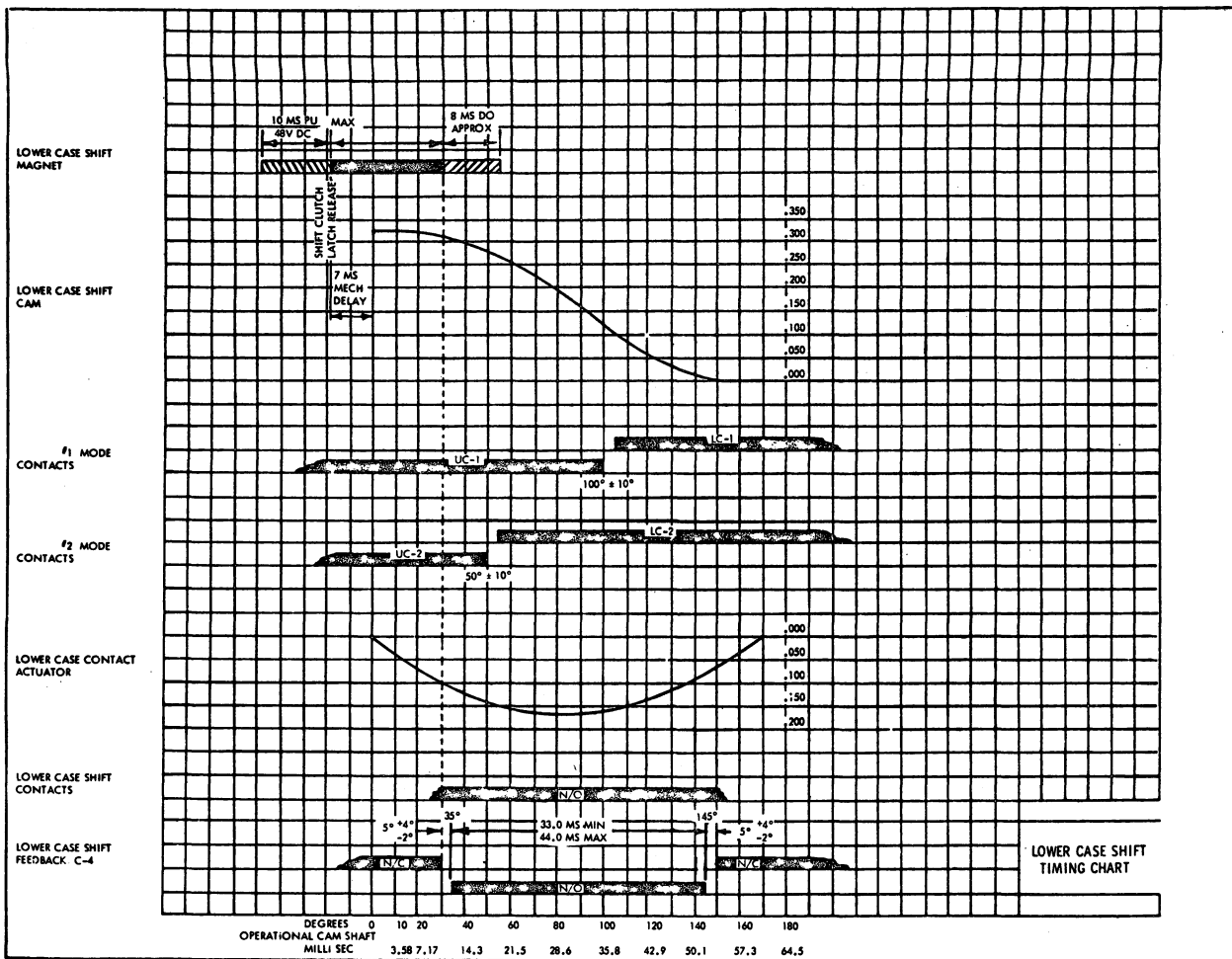

CORRESPONDENCE WIRING DIAGRAM

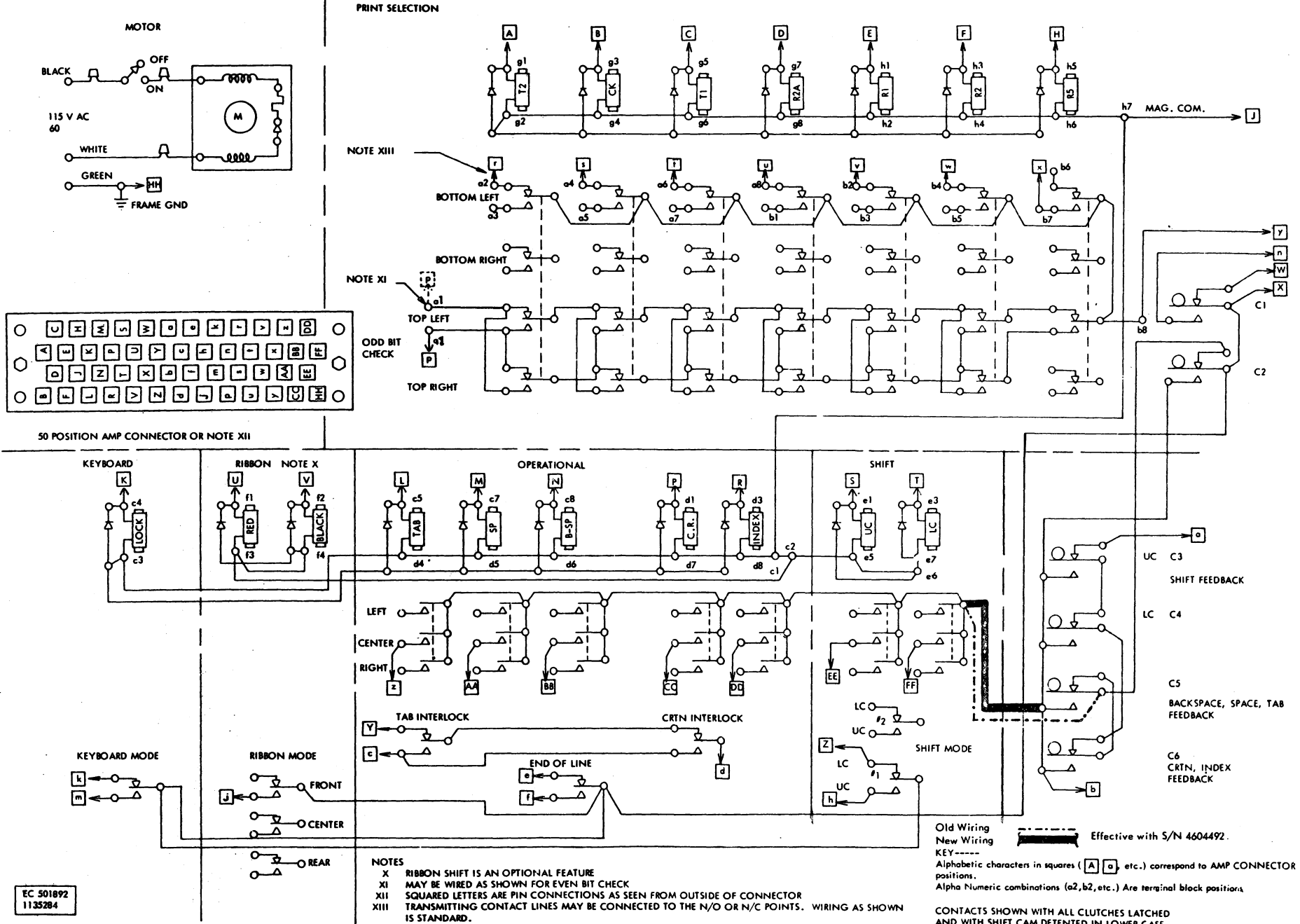

EC 501892
1135284

MT/ST WIRING DIAGRAM

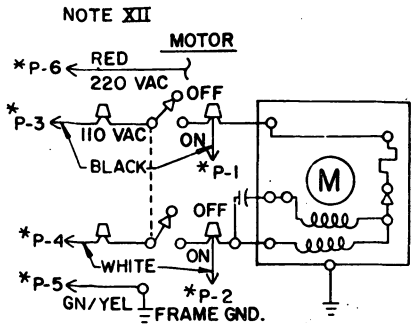

PRINT SELECTION

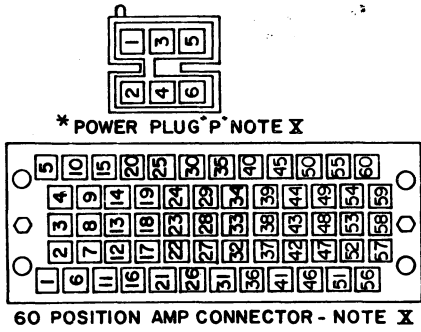
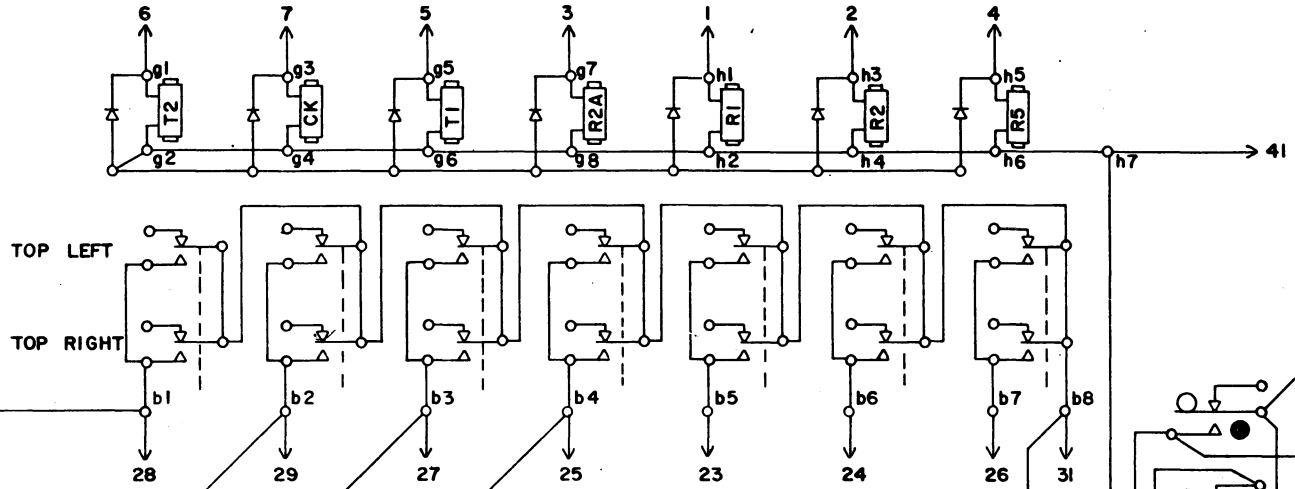

KEYBOARD

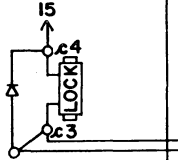

NOTES

- DENOTES TUNGSTEN CONTACTS
- X SQUARED NUMBERS ARE PIN CONNECTIONS AS SEEN FROM OUTSIDE OF CONNECTOR

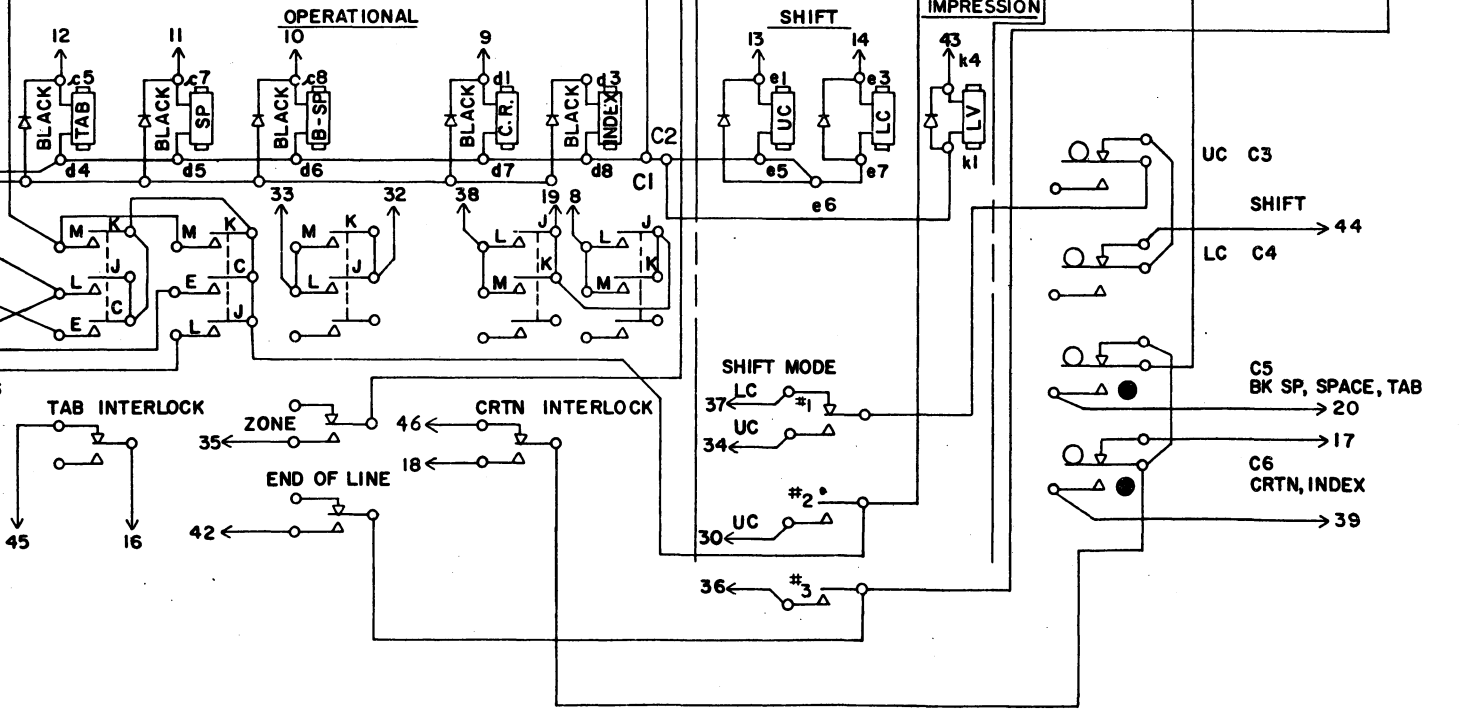

BCD WIRING DIAGRAM

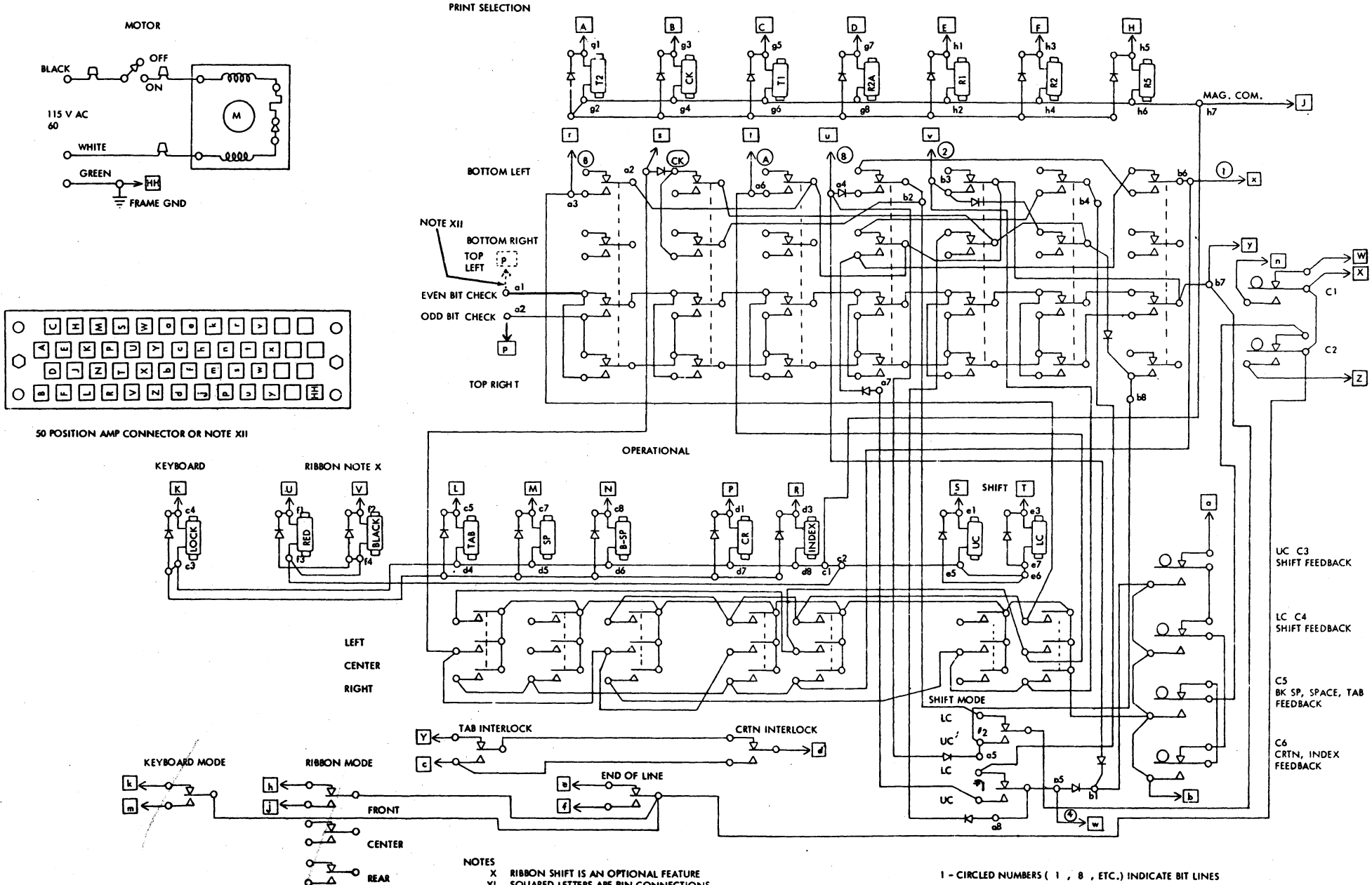

1 - CIRCLED NUMBERS (1 , 8 , ETC.) INDICATE BIT LINES

2 - CONTACTS SHOWN WITH ALL CLUTCHES LATCHED AND WITH SHIFT CAM DETENTED IN LOWER CASE

3- Alphabetic characters in squares ([A] a , etc.) correspond to AMP CONNECTOR positions.

4-7

SELECTION AND TILT-ROTATE SCHEDULE																						
BCD KEYBOARD						CORRESPONDENCE KEYBOARD																
U C	L C	T 2	C K	T 1	R 2 A	R 1	R 2	R 5	TLT	ROT		U C	L C	T 2	C K	T 1	R 2 A	R 1	R 2	R 5	TLT	ROT
■	A	0	1	0	1	1	1	1	3	-5		A	a	0	0	1	1	0	0	1	2	-2
■	B	0	1	0	1	0	1		3	+1		B	b	1	0	0	0	0	0		1	+5
■	C	0	0	0	1	0	1	1	3	-4		C	c	1	0	0	1	0	0	1	1	-2
■	D	0	1	0	1	1	0		3	+2		D	d	1	1	0	1	1	0	1	1	-3
■	E	0	0	0	1	1	0	1	3	-3		E	e	1	0	0	1	1	0		1	+2
■	F	0	0	0	1	0	0		3	+3		F	f	0	0	0	1	0	1	1	3	-4
■	G	0	1	0	1	0	0	1	3	-2		G	g	0	1	0	1	1	1	1	3	-5
■	H	0	1	0	0	1	0	1	3	-1		H	h	1	1	0	0	1	0		1	+4
■	I	0	0	0	0	1	0		3	+4		I	i	0	1	1	1	0	0		2	+3
■	J	0	0	1	1	1	1	1	2	-5		J	j	0	0	0	1	1	1		3	0
■	K	0	0	1	1	0	1		2	+1		K	k	1	1	0	1	0	0		1	+3
■	L	0	1	1	1	0	1	1	2	-4		L	l	1	0	0	1	0	1	1		-1
■	M	0	0	1	1	1	0		2	+2		M	m	0	0	1	1	1	1	1	2	-5
■	N	0	1	1	1	1	0	1	2	-3		N	n	1	0	0	1	0	1		1	+1
■	O	0	1	1	1	0	0		2	+3		O	o	0	0	1	0	1	0	1	2	-1
■	P	0	0	1	1	0	0	1	2	-2		P	p	0	1	0	1	1	0		3	+2
■	Q	0	0	1	0	1	0	1	2	-1		Q	q	0	0	0	1	0	0		3	+3
■	R	0	1	1	0	1	0		2	+4		R	r	0	1	1	1	1	0	1	2	-3
■	S	1	0	0	1	0	1		1	+1		S	s	0	1	1	0	1	0		2	+4
■	T	1	1	0	1	0	1	1	1	-4		T	t	1	1	0	1	1	1		1	0
■	U	1	0	0	1	1	0		1	+2		U	u	1	1	0	1	0	1	1	1	-4
■	V	1	1	0	1	1	0	1	1	-3		V	v	0	1	1	1	0	1	1	2	-4
■	W	1	1	0	1	0	0		1	+3		W	w	0	0	1	0	0	0		2	+5
■	X	1	0	0	1	0	0	1	1	-2		X	x	1	0	0	1	1	1	1	1	-5
■	Y	1	0	0	0	1	0	1	1	-1		Y	y	0	0	0	0	1	0		3	+4
■	Z	1	1	0	0	1	0		1	+4		Z	z	1	0	1	1	1	1		0	0
■	1	1	1	1	1	1	1	1	1	-5		[]	1	1	1	1	1	1	1	0	-5
■	2	1	1	1	1	0	1		0	+1		@	2	1	1	1	1	0	1		0	+1
■	3	1	0	1	1	0	1	1	0	-4		#	3	1	0	1	1	0	1	1	0	-4
■	4	1	1	1	1	1	0		0	+2		\$	4	1	1	1	0	1	0	1	0	-1
■	5	1	0	1	1	1	0	1	0	-3		%	5	1	1	1	1	1	0		0	+2
■	6	1	0	1	1	0	0		0	+3		^	6	1	0	1	1	0	0		0	+3
■	7	1	1	1	1	0	0	1	0	-2		&	7	1	0	1	1	1	0	1	0	-3
■	8	1	1	1	0	1	0	1	0	-1		*	8	1	1	1	1	0	0	1	0	-2
■	9	1	0	1	0	1	0		0	+4		(9	1	1	1	0	0	0		0	+5
■	>	1	0	1	0	0	0	1	0	0)	0	1	0	1	0	1	0		0	+4
■	-	0	1	1	1	1	1		2	0		_	-	0	1	0	0	0	0		3	+5
■	#	1	1	1	0	0	0		0	+5		+	=	0	1	0	1	0	1		3	+1
■	&	1	1	0	1	1	1		1	0		*	!	0	1	1	1	1	1		2	0
■	ε	0	0	0	1	1	1		3	0		:	;	0	0	0	1	1	0	1	3	-3
■	\$	0	0	1	0	0	0		2	+5		"	'	0	0	1	1	1	0		2	+2
■	,	1	0	0	0	0	0		1	+5		,	,	0	1	0	1	0	0	1	3	-2
■	.	0	1	0	0	0	0		3	+5		.	.	0	0	1	1	0	1		2	+1
■	/	1	0	0	1	1	1	1	1	-5		?	/	0	1	0	0	1	0	1	3	-1

0 in Square* - Indicates; 1. Selection Contact Transferred
2. Latches Active

1 in Square* - Indicates Selection Magnet Energized

*Exception - 1 in R5 Column Indicates Both Selection Contact Transferred and Magnet Energized.

TYPEHEAD LAYOUT

T - #s = Tilt latches active
R - #s = Rotate latches active

Upper Case												Lower Case												
-5	-4	-3	-2	-1	0	+1	+2	+3	+4	+5	-5	-4	-3	-2	-1	0	+1	+2	+3	+4	+5			
■	■	■	■	■	@	>	■	■	■	■	:	Y	1	3	5	7	8	0	2	4	6	9	#	T-0
■	■	■	■	■	+%	/	■	■	■	■	3	#	T	V	X	Y	8	5	U	W	Z	,	T-1	
■	■	■	■	■	1	:	■	■	■	■	■	■	J	L	N	P	Q	-	K	M	O	R	\$	T-2
■	■	■	■	■	? :	^	■	■	■	■	■	■	A	C	E	G	H	6	B	D	F	I	.	T-1,2
R-5	R-5,1	R-5,2	R-5,2,1	R-5,2,2A	*	R-1	R-2	R-1,2	R-2,2A	R-1,2,2A	R-5	R-5,1	R-5,2	R-5,2,1	R-5,2,2A	*	R-1	R-2	R-1,2	R-2,2A	R-1,2,2A			
[#	&	~	\$	Z	@	%	^)	(]	3	7	8	4	z	2	5	6	0	9	T-0		
X	U	D	C	L	T	°	N	E	K	H	B	x	u	d	c	i	t	n	e	k	h	b	T-1	
M	V	R	A	O	°	"	I	S	W	m	v	r	a	o	!	=	'	i	s	w	T-2			
G	F	:	,	? :	J	+	P	Q	Y	-	g	f	;	/	;	/	i	=	p	q	y	-	T-1,2	
					HOME											HOME								

*With one exception, home position (Zero Rotate) selection on the 73 Series is identical to the 72 Series - i.e., no rotate latches are active. On the BCD machine, home position, during zero tilt only (0 & >), is selected by the cancellation method - i.e., all rotate latches are active (see the Selection and Tilt Rotate Schedule)

On the BCD machine only, the symbol > (Greater Than) may be used to check type head homing.

BCD MACHINE									
CHARACTER	CASE	ALPHABETIC & NUMERIC BIT CODE						NOTE	
		1	2	4	8	A	B		C
A	U								1
A	L	1	0	0	0	1	1	0	1
B	U								1
B	L	0	1	0	0	1	1	0	1
C	U								1
C	L	1	1	0	0	1	1	1	1
D	U								1
D	L	0	0	1	0	1	1	0	1
E	U								1
E	L	1	0	1	0	1	1	1	1
F	U								1
F	L	0	1	1	0	1	1	1	1
G	U								1
G	L	1	1	1	0	1	1	0	1
H	U								1
H	L	0	0	1	1	1	1	0	1
I	U								1
I	L	1	0	1	1	1	1	0	1
J	U								1
J	L	1	0	0	0	0	1	1	1
K	U								1
K	L	0	1	0	0	0	1	1	1
L	U								1
L	L	1	1	0	0	0	1	0	1
M	U								1
M	L	0	0	1	0	0	1	1	1
N	U								1
N	L	1	0	1	0	0	1	0	1
O	U								1
O	L	0	1	1	0	0	1	0	1
P	U								1
P	L	1	1	1	0	0	1	1	1
Q	U								1
Q	L	0	0	0	1	0	1	1	1
R	U								1
R	L	1	0	1	1	0	1	1	1
S	U								1
S	L	0	1	0	0	1	0	1	1
T	U								1
T	L	1	1	0	0	1	0	0	1
U	U								1
U	L	0	0	1	0	1	0	1	1
V	U								1
V	L	1	0	1	0	1	0	0	1
W	U								1
W	L	0	1	1	0	1	0	0	1
X	U								1
X	L	1	1	1	0	1	0	1	1
Y	U								1
Y	L	0	0	1	1	1	0	0	1
Z	U								1
Z	L	1	0	0	1	1	0	0	1
1	U								1
1	L	1	0	0	0	0	0	0	1
2	U								1
2	L	0	1	0	0	0	0	0	1
3	U								1
3	L	1	1	0	0	0	0	1	1
4	U								1
4	L	0	0	1	0	0	0	0	1
5	U								1
5	L	1	0	1	0	0	0	1	1
6	U								1
6	L	0	1	1	0	0	0	1	1
7	U								1
7	L	1	1	1	0	0	0	0	1
8	U								1
8	L	0	0	1	1	0	0	1	1
9	U								1
9	L	1	0	1	1	0	0	0	1
@	U								1
@	L	0	1	1	1	0	0	0	1
#	U								1
#	L	0	1	0	1	0	0	1	1
\$	U								1
\$	L	0	1	1	1	1	1	0	1
%	U								1
%	L	0	0	0	0	1	0	1	1
&	U								1
&	L	0	0	1	1	1	1	1	1
'	U								1
'	L	1	1	1	1	0	1	0	1
(U								1
(L	1	1	1	1	1	0	0	1
)	U								1
)	L	1	1	0	1	1	1	0	1
*	U								1
*	L	1	1	0	1	1	1	0	1
/	U								1
/	L	1	0	0	0	1	0	1	1

NOTES:

- Selecting this type head position in upper case will generate an invalid code. The Bit Check may appear either odd or even.
- Bits are formed by contact closure (print selection transmitting and shift mode) between terminal "Y" and the bit lines (see BCD Wiring Diagram, page 20).
- All bits formed by selection of any alphabetic or numeric character are indicated by "1".

BCD MACHINE								
OPERATION	OPERATIONAL BIT CODE							
	1	2	4	8	A	B	C	K
Space	1	0	1	1	0	0	0	
Backspace	0	1	1	1	0	1	1	
Tab	1	0	1	1	1	0	1	
C. R.	1	0	1	1	0	1	1	
Index	1	0	1	1	1	1	0	
U.C. SH.	0	1	1	1	0	0	0	
L.C. SH.	0	1	1	1	1	1	0	

NOTES:

- Both a 4 and an 8 Bit are transmitted during each operational function. Closing any N/O operational feedback contact (C3, C4, C5, or C6) connects terminal X (see BCD Wiring Diagram, page 7) to lines 4 and 8.
- All other bits for operational functions are generated by closure of the operational transmitting contacts and are gated by either C3, C4, C5, or C6.

BCD MACHINE				
CONTACTS INVOLVED IN GENERATION OF ALPHA-NUMERIC BITS				
BIT	TERM. IN	THROUGH DIODES, PRINT SELECTION TRANSMITTING AND SHIFT MODE CONTACTS	TERM. OUT	CASE
1	1	R5 N/C & R2A* N/O R5 N/O & R2A N/C & #2 N/C	y	U or L L
2	2	R1 N/O D & R2* N/C & D & #2 N/O	y	U or L U
4	4	#1 N/O & D & R2A* N/O #1 N/C & R2 N/O & R2A* N/C D & R1* N/C & D & #2 N/O	y	U L U
8	8	D & #2 N/O D & R2A N/O & #2 N/C	y	U L
A	A	T1 N/O	y	U or L
B	B	T2 N/O	y	U or L
CK	CK	D & CK* N/O & #2 N/C D & CK N/C & D & #2 N/O	y	L U

NOTES:

- Asterisked (*) rotate contacts are bottom right - all others are bottom left.
- Circuits through N/O Tilt, Rotate, and #1 & #2 Mode contacts indicate that the contact is transferred.
- Circuits through N/C Tilt, Rotate, and #1 & #2 Mode contacts indicate that the contact is not transferred.

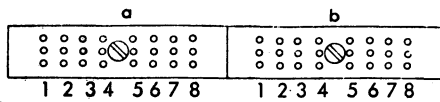

SEL CONT TERM BLOCK

TERMINAL END VIEW OF SELECTION CONTACTS

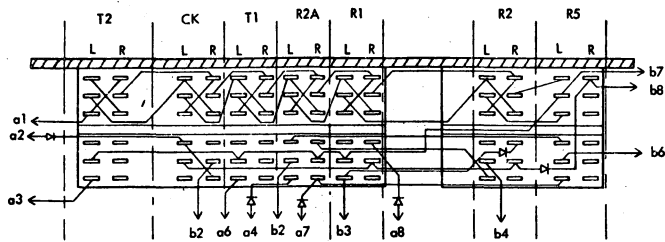

BCD

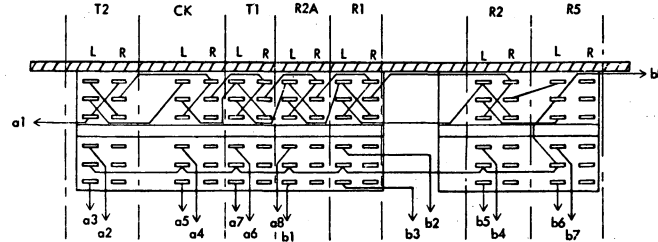

CORRESPONDENCE

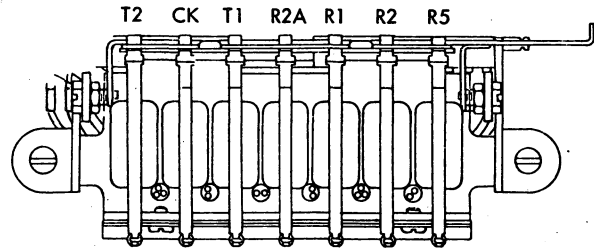

SEL MAGS

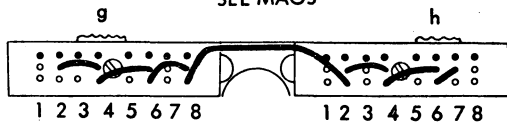

SEL MAG TERM BLOCK

SELECTION MAGNET WIRING CHART		
COIL	BLACK LEAD	WHITE LEAD
T2	g-2	g-1
CHECK	g-4	g-3
T1	g-6	g-5
R2A	g-8	g-7
R1	h-2	h-1
R2	h-4	h-3
-R5	h-6	h-5

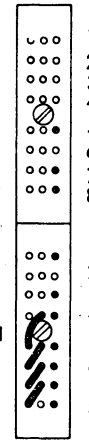

OPER TERM BLOCK

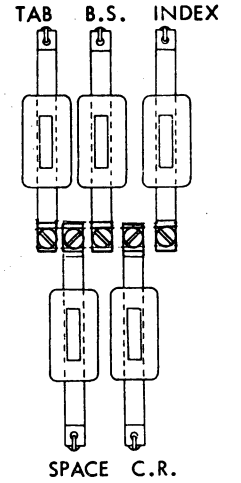

OPER MAGS

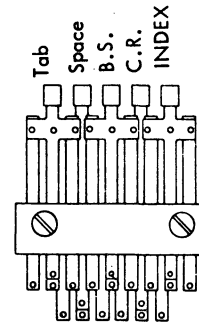

OPERATIONAL TRANSMITTING CONTACTS

OPERATIONAL MAGNET WIRING CHART		
COIL	BLACK LEAD	WHITE LEAD
TAB	d-4	c-5
SPACE	d-5	c-7
BACKSPACE	d-6	c-8
CARRIER RETURN	d-7	d-1
INDEX	d-8	d-3